

ICSA2-YGH Cartesian Robot: Y-Z 2-Axes Configuration, YZ (Z-Axis Slider Mount) Type

ICSPA2-YGH Cartesian Robot: Y-Z 2-Axes Configuration, YZ (Z-Axis Slider Mount) Type **High-Precision Specification**

Type YZ type Stroke Y-axis: 200-700mm Z-axis: 100-500mm Load capacity 27kg ~ 20.7kg

Model specification items Series Type Encoder type Y-axis stroke + options Z-axis stroke + options Applicable controller Cable length Cable management
 ICSA2 - YCH - A - 70AQLNM - 50AQLB - T1 - 5L - SC

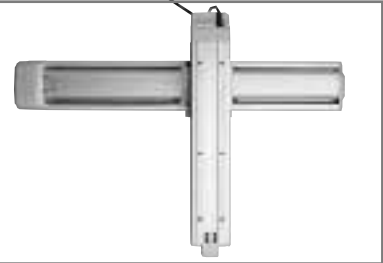

* Refer to page 61 for the details of model specification items.

Models/Specifications

Model	Axis configuration		Encoder type	Motor output (W)	Lead (mm)	Stroke (mm) In increments of 100mm	Speed (mm/s)	Load capacity (Note 1)	Positioning repeatability (mm) (Note 2)
ICSA2 [ICSPA2] -YGH-A-***-***B-T1-Δ-SC	Y-axis	ISA [ISPA] -LYM-A-400-20-***-T1	Absolute	400	20	200 ~ 700	1 ~ 1000	27 ~ 20.7	±0.02 [±0.01]
	Z-axis	ISA [ISPA] -LZM-A-400-10-***-T1-B			10	100 ~ 500	1 ~ 500		
ICSA2 [ICSPA2] -YGH-I-***-***B-T1-Δ-SC	Y-axis	ISA [ISPA] -LYM-A-400-20-***-T1	Incremental		20	200 ~ 700	1 ~ 1000		
	Z-axis	ISA [ISPA] -LZM-A-400-10-***-T1-B			10	100 ~ 500	1 ~ 500		

* In the above model names, *** indicates the stroke/applicable options (stroke is specified in centimeters), and Δ the cable length.

Options

Name	Code	Page	Remarks
AQ seal	AQ	→ P13	
Brake	B	→ P13	Standard equipment on Z-axis
Creep sensor	C	→ P13	
Home limit switch	L	→ P14	
Reverse homing specification	NM	→ P14	
Guide with ball-retaining mechanism	RT	→ P14	

Common Specifications

Drive system (Note 3)	Ball screw, rolled C10 [equivalent to rolled C5]
Backlash (Note 4)	0.05mm or less [0.02mm or less]
Guide	Integrated with base
Base	Material: Aluminum with white alumite treatment
Cable length (Note 5)	3L: 3m, 5L: 5m, □ L : Length specification
Cable management	SC: Self-standing cable

Load Capacity by Acceleration (kg)

Z-axis stroke (mm) \ Acceleration (G)	100	200	300	400	500
0.3	27.0	25.5	23.9	22.3	20.7
0.4	20.1	18.6	17.0	15.4	13.8
0.5	15.6	14.1	12.5	10.9	9.3
0.6					
0.7					
0.8					
0.9					
1.0					

Maximum Speed by Stroke (mm/sec)

Axis \ Stroke (mm)	100	200 ~ 500	600 ~ 700
Y-axis	-	1000	
Z-axis	500		-

Applicable Controller Specifications

Applicable controller	Controller type	Model	Page
X-SEL	General-purpose type	XSEL-K-2-400□-400B□-□-□□□-□-□	→ P241
	Compact type	XSEL-J-2-400□-400B□-□-□□□-□-□	→ P241

Caution

(Note 1) The load capacity assumes operation at the rated acceleration (0.3 G). The actuator can be operated at accelerations beyond the rated acceleration, but the load capacity will decrease (refer to the table of load capacity by acceleration).
 (Notes 2, 3, 4) The figures in brackets apply to the ICSPA2.
 (Note 5) The cable length measures from the X-axis connector box to the controller. The standard lengths are 3 m and 5 m, but other lengths can also be specified in meters up to 20 m (e.g., 10L = 10 m).

* Refer to page 59 for other points to note.

Self-standing Cable Specification (Cable Management Code: SC)

Dimensions

* Note that changing the home direction will require the actuator to be returned to IAI for adjustment.

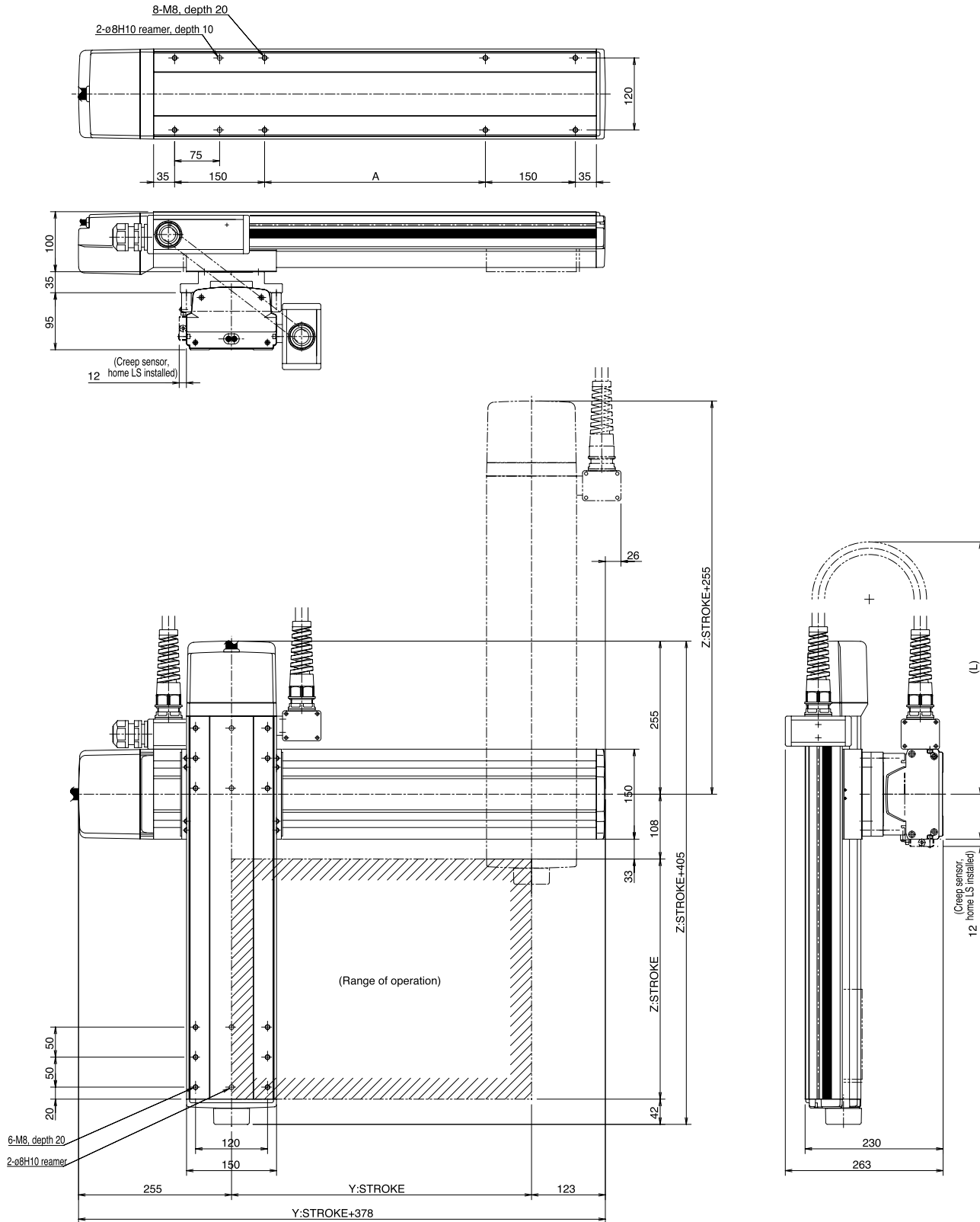

Dimension L							
Zst \ Yst	200	300	400	500	600	700	
100	500	550	600	650	700	750	
200	600	650	700	750	800	850	
300	700	750	800	850	900	950	
400	800	850	900	950	1000	1050	
500	900	950	1000	1050	1100	1150	
Y stroke	200	300	400	500	600	700	
A	438	538	638	738	838	938	

Single-Axis Robots

Cartesian Robots

Controllers