

# **P-Driver**

PULSE DRIVE

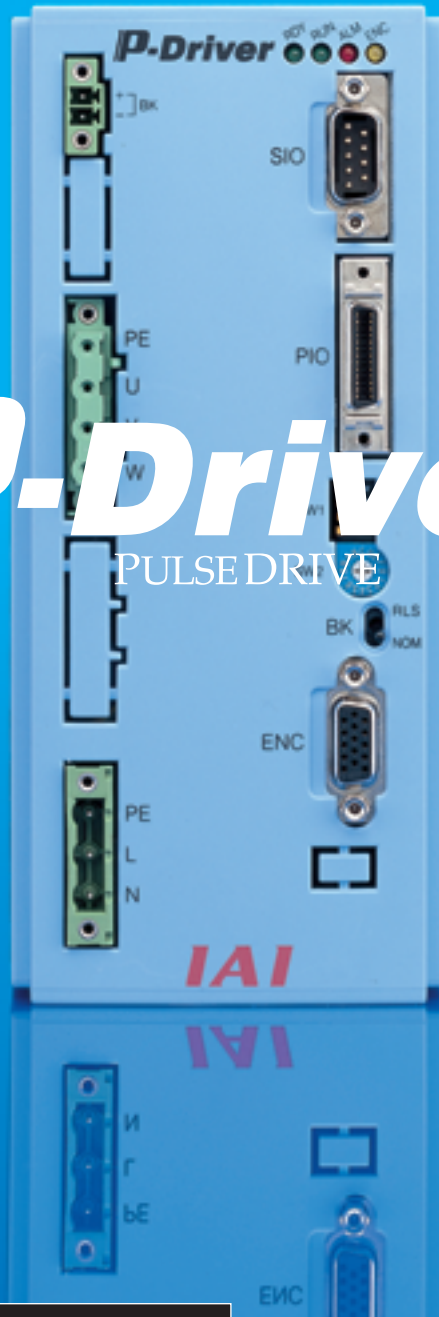

AGENT

**IAI America, Inc.**





Pulse-Train Input Driver for Positioning

# P-Driver

P-Driver is a pulse-train input driver that enables flexible operation of IAI's ROBO CYLINDER and single-axis robots. (Note 1)



(Note 1) Certain types of ROBO CYLINDER cannot be operated by P-Driver. See the table below for the compatible actuator types.

| Controller                   |  | <b>P-Driver</b><br> | <b>E-Con</b><br> | <b>RCS-C</b><br> | <b>RCP-C</b><br> |  |
|------------------------------|--|--|---|---|---|--|
| Positioning command          |  | Pulse train (Sequence control)   | PIO (Position number)   |   |   |  |
| Number of positioning points |  | No limitation  | 64 points   | 16 points   | 16 points   |  |
| Input power supply           |  | 100VAC<br>200VAC   | 100VAC<br>200VAC  | 100VAC<br>200VAC<br>24VDC   | 24VDC   |  |
| Compatible actuators         | RCP  |  |   |   | ○   |  |
|                              | RCS-SA4/SA5/SA6  |  |   |   | ○   |  |
|                              | RCS-RA35/RA45  |  |   |   | ○   |  |
|                              | RCS-RB7525   |  |   |   | ○   |  |
|                              | RCS-SS/SM  | ○  | ○   | ○   |   |  |
|                              | RCS-SSR/SMR  | ○  | ○   | ○   |   |  |
|                              | RCS-RA55/F55   | ○  | ○   | ○   |   |  |
|                              | RCS-RB7530<br>RB7535   | ○  |   | ○   |   |  |
|                              | DS (T1 specification)  | ○  |   |   |   |  |
|                              | SS<br>IS/ISP<br>ISD<br>ISD-CR<br>ISPD-CR<br>IF<br>FS<br>(All T1 specification) |  |   |   |   |  |
|                              | 12RS (T1 type)   | ○  |   |   |   |  |
|                              | RCS-R10I<br>RCS-R20I<br>RCS-R30I<br>RCS-G20I                                   | ○<br>○<br>○<br>○   |   | ○<br>○<br>○<br>○  |   |  |

## Flexible Control of IAI's ROBO CYLINDER and Single-Axis Robots Using Pulse Train

- The P-Driver can control a wide range of ROBO CYLINDERS and single-axis robots in desired manners. (Motor wattage: 20W to 750W, Strokes: 50mm to 3,000mm)
- The P-Driver comes fully assembled and pre-formatted to the specific actuator ordered. Cost, assembly time and design time can be reduced as compared to integrating a system in-house by assembling the ballscrew, motor, linear guides and various other parts.
- Pulse-train control puts no limitation on the number of positioning points.

### Dedicated Homing Signal

The dedicated homing input enables automatic homing without programming a complex sequence.

### Torque Limiting Function

Torque can be limited using external signal (via parameter setting). Signal is output when the specified torque is reached. Push operation and press-fitting become possible with the use of this function.

### Brake Control Function

- The actuator's brake (optional) is controlled via a dedicated circuit inside the controller. There is no need to program a special sequence.
- With the use of a dedicated power supply (24 VDC), the brake can be forcibly released while the driver's main power is off.

### Feedback Function

- Position detection data can be output in pulse trains (differential output). This enables reading of the current position in real time from the host controller.

### Feed-Forward Control Function

- Response can be improved under certain conditions when the load inertia ratio is high. Increasing the parameter setting decreases the deviation, thus resulting in improved response. (Deviation is the difference between the position command and the position feedback.)

### Position-Command Primary Filter Function

- Soft start and stop are possible even with command pulse inputs for which acceleration/deceleration is not specified.

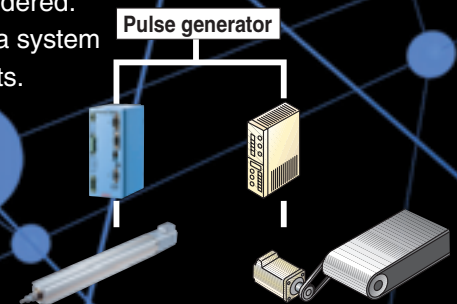

Model

# PDR-I-100 B-1-P

- ① Series PDR: P-Driver
- ② Encoder type I: Incremental
- ③ Motor capacity 20: 20W / 30: 30W / 60: 60W / 100: 100W / 150: 150W / 200: 200W / 400: 400W / 600: 600W / 750: 750W
- ④ Options (Blank): None / B: Brake / C: Creep sensor / L: Limit switch
- ⑤ Power-supply voltage 1: 100V / 2: 200V
- ⑥ I/O method (Blank): NPN specification / P: PNP specification

## System Configuration

### Compatible Actuators:

- Ballscrew Drive Type DS/SS/IS/ISP/ISD
- Belt Drive Type IF/FS
- Clean Room Type ISD-CR/ISPD-CR
- ROBO CYLINDER Slider Type RCS-SS/SSR/SM/SMR
- ROBO CYLINDER Rod Type RCS-RA55/RB7530/RB7535
- ROBO CYLINDER Flat Type RCS-F55
- ROBO Rotary RCS-R10I/20I/30I
- ROBO Gripper RCS-G20I

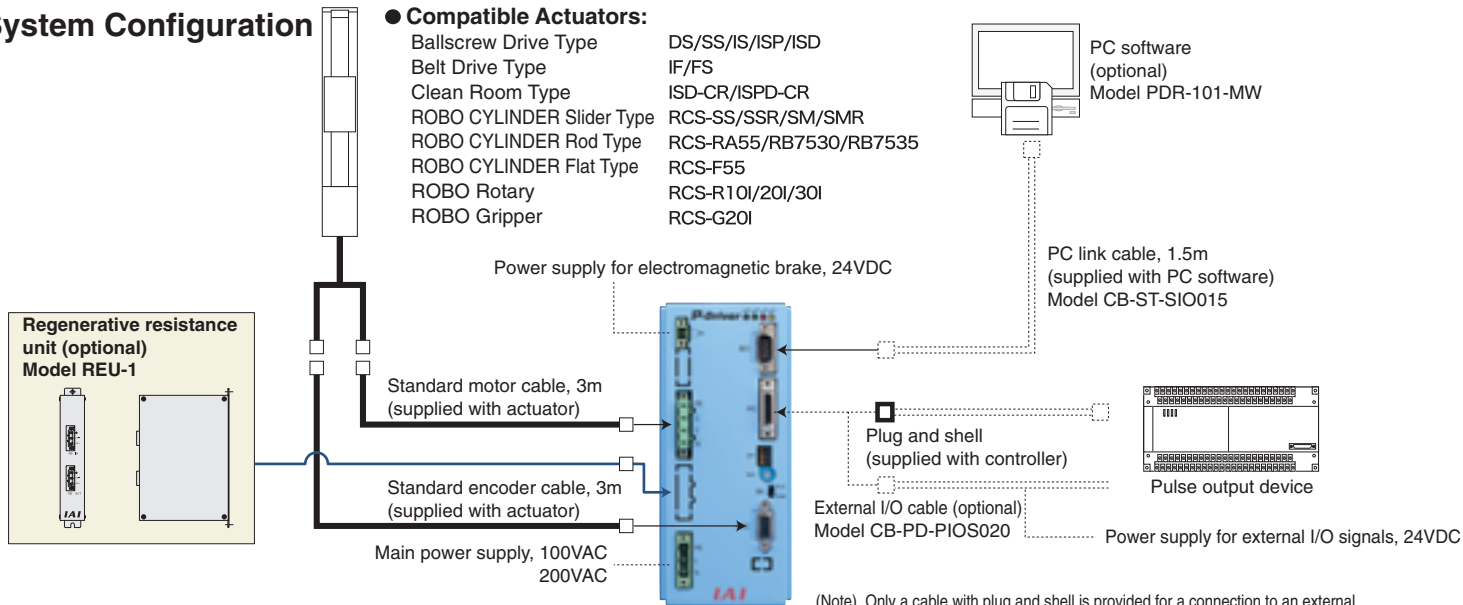

(Note) Only a cable with plug and shell is provided for a connection to an external device. Solder the cable or use an optional external I/O cable.

## Options

### PC software Model PDR-101-MW

Content: Floppy disks, PC link cable 1.5m (Unit model CB-ST-SIO015)

Used to set P-Driver parameters, monitor jogging operation during debugging, check various signals, and so on.

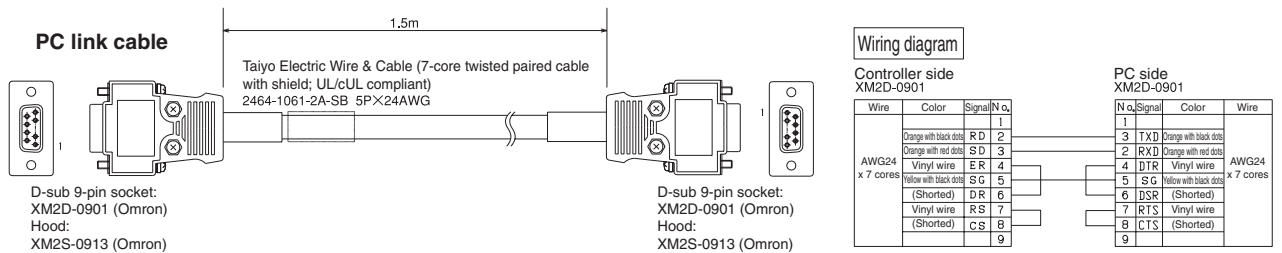

### External I/O cable Model CB-PD-PIOS020

Content: Plug, shell and 2-m shielded cable (no connector at end)  
Use this cable for connection with a pulse output device.

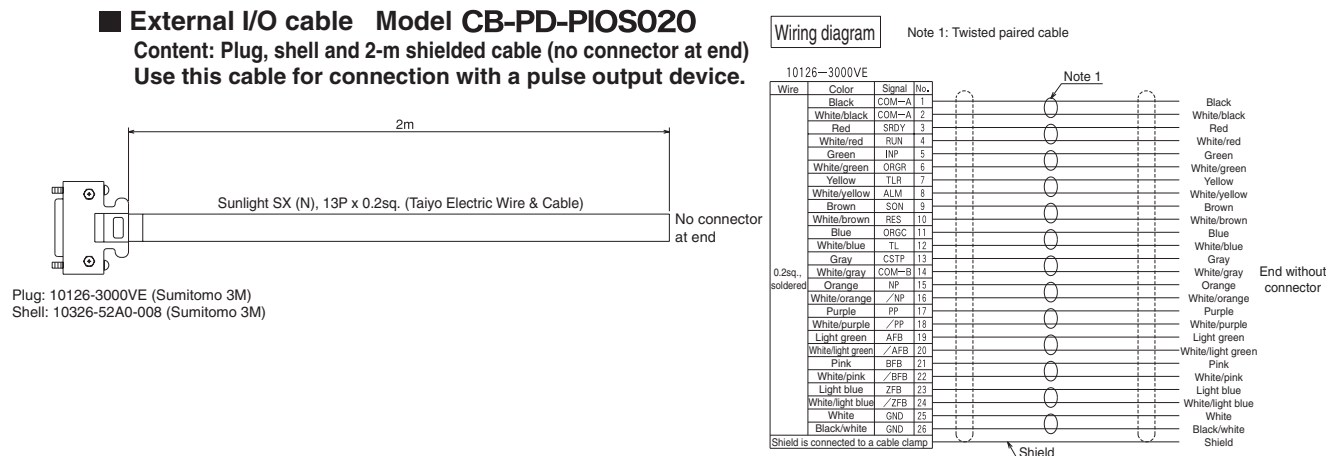

**Name of Each Part**

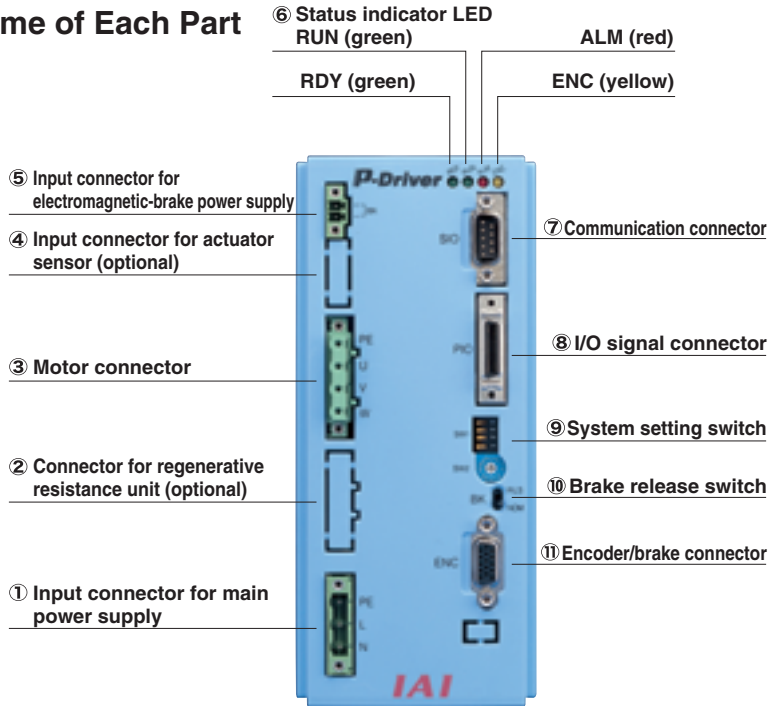

- ① **Input connector for main power supply** ... Connects the power supply.
- ② **Connector for regenerative resistance unit** ... Connects a regenerative resistance unit (optional).
- ③ **Motor connector** ... Connects the actuator's motor cable.
- ④ **Input connector for actuator sensor** ... Connects cables from the actuator's sensors such as LS, CREEP and OT (optional).
- ⑤ **Input connector for electromagnetic-brake power supply** ... Connects the power supply for electromagnetic brake.  
(An electromagnetic brake requires an external power supply.)
- ⑥ **Status indicator (LED)** ... Used to monitor the controller's operating condition.
- ⑦ **Communication connector** ... Connects the PC software cable.
- ⑧ **I/O signal connector** ... Connects the control I/O signals.
- ⑨ **System setting switch** ... This switch is used to change the encoder voltage and for remote start operation. (The rotary switch is used for adjustment by the manufacturer.)
- ⑩ **Brake release switch** ... This switch is used to forcibly release the brake.
- ⑪ **Encoder/brake connector** ... Connects the actuator's encoder/brake cable.

**Specification Table**

|  |  |   |    |     |     |     |     |     |      |      |
|--|--|---|----|-----|-----|-----|-----|-----|------|------|
| Actuator motor capacity (W)            | 20   | 30  | 60 | 100 | 150 | 200 | 400 | 600 | 750  |      |
| Power capacity                         | (W)  | 34  | 42 | 100 | 150 | 210 | 270 | 520 | 770  | 1000 |
|  | (VA)   | 57  | 70 | 160 | 240 | 350 | 450 | 870 | 1300 | 1600 |
| Input power supply                     | 100V specification: single-phase, 100 to 115VAC ±10%, 50/60Hz                                    |   |    |     |     |     |     |     |      |      |
|  | 200V specification: single-phase, 200 to 230VAC ±10%, 50/60Hz                                    |   |    |     |     |     |     |     |      |      |
| Control method                         | Sine wave PWM, vector current control  |   |    |     |     |     |     |     |      |      |
| Position detection method              | Incremental encoder  |   |    |     |     |     |     |     |      |      |
| Braking method                         | Regenerative resistance  |   |    |     |     |     |     |     |      |      |
| Function/performance                   | Control mode   | Position control via pulse-train input                      |    |     |     |     |     |     |      |      |
|  | Maximum input pulse frequency  | Max. 500kpps (differential) / Max. 200kpps (open-collector) |    |     |     |     |     |     |      |      |
|  | Command pulse magnification (electronic gear: A/B)   | A, B = 1 to 4096<br>1/50 < A/B < 50/1 (parameter setting)   |    |     |     |     |     |     |      |      |
|  | Positioning completion width   | 1 to 4096 pulses (parameter setting)                        |    |     |     |     |     |     |      |      |
| Power supply for I/O signal I/F        | 24VDC ±20%, 0.8A (supplied externally)   |   |    |     |     |     |     |     |      |      |
| Power supply for electromagnetic brake | 24VDC ±20%, 1A (peak value) (supplied externally)  |   |    |     |     |     |     |     |      |      |
| Communication function                 | RS232C (for dedicated PC software)   |   |    |     |     |     |     |     |      |      |
| Protection functions                   | Motor overvoltage, overcurrent, abnormal driver temperature, encoder error, motor overload, etc. |   |    |     |     |     |     |     |      |      |
| Environmental conditions               | Operating temperature/humidity   | 0 to 40°C, 85%RH or less (non-condensing)                   |    |     |     |     |     |     |      |      |
|  | Storage temperature  | -20 to 70°C (non-condensing)                                |    |     |     |     |     |     |      |      |
|  | Operating ambience   | Free from corrosive or flammable gases, oil mist or dust.   |    |     |     |     |     |     |      |      |
|  | Durability/vibration   | 4.9m/s <sup>2</sup>   |    |     |     |     |     |     |      |      |
| Insulation resistance                  | 1500VAC for 1 minute (1000VAC for 1 minute with actuator connected)                              |   |    |     |     |     |     |     |      |      |
| Protection structure                   | Open, forced air cooling (IP20)  |   |    |     |     |     |     |     |      |      |
| Weight                                 | 1.2kg  |   |    |     |     |     |     |     |      |      |

**Regenerative Resistance Unit**

■ Model **REU-1**

■ **Features** • This unit converts the regenerative current that generates when the motor decelerates into heat. A regenerative resistor is installed in the controller, but its capacity may not be sufficient if a large load is supported on a vertical axis. In this case, a separate regenerative resistance unit is required.

■ **Specifications**

| Item  | Specification                                  |
|---|--|
| Unit dimensions                             | W34mm×H195mm×D126mm                            |
| Unit weight                                 | 0.9kg  |
| Ratings of built-in regenerative resistance | 220Ω 80W                                       |
| Accessory                                   | Controller link cable (Model CB-ST-REU010), 1m |

■ **Installation Standards**

| Motor wattage | Horizontal application |
|---------------|------------------------|
| 20~150W       | Not required.          |
| 200~600W      |                        |
| 750W          |                        |

\*The above table shows reference values when the driver is used in the rated conditions (load capacity, speed and acceleration).

■ **Dimensions**

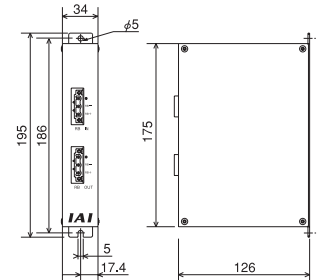

### Interface Circuit

#### Sequence input part

| Item                          | Description  |
|-------------------------------|--|
| Number of input signal points | 5 points   |
| Input voltage                 | 24VDC $\pm$ 20%  |
| Input current                 | 7mA/point  |
| Operating voltage             | ON voltage ... Min. 16V (4.5mA)<br>OFF voltage ... Max. 6V (1.4mA) |
| Insulation method             | Photo-coupler  |

#### NPN specification

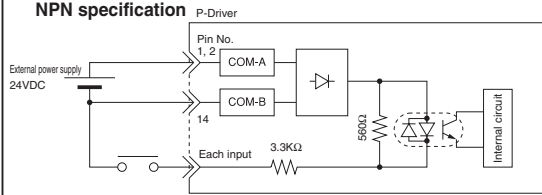

#### PNP specification

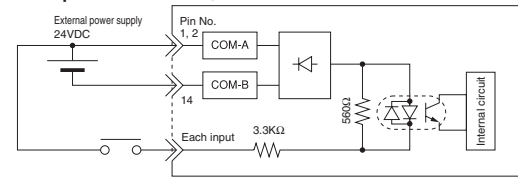

#### Sequence output part

| Item                           | Description                             |
|--------------------------------|---|
| Number of output signal points | 6 points                                |
| Rated load voltage             | 24/60VDC (peak; without flywheel diode) |
| Maximum load current           | 100mA/point                             |
| Residual voltage               | 1.8V/100mA                              |
| Insulation method              | Photo-coupler                           |
| Overcurrent protection         | Fuse resistance: 10Ω, 0.1W              |

#### NPN specification

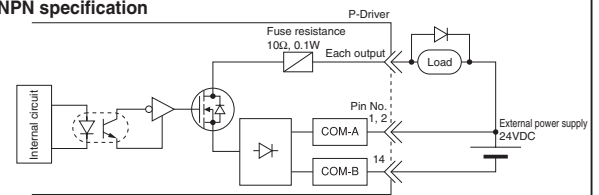

#### PNP specification

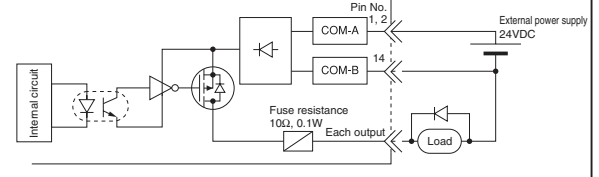

### Command Pulse-Train Input Part

#### Differential line-driver input

Applicable line driver: 26C31 or equivalent

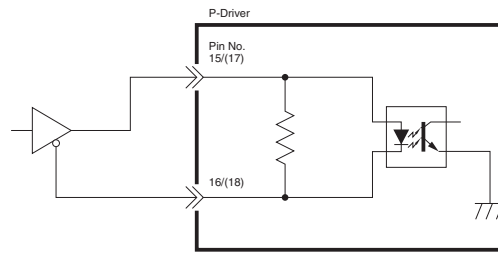

#### Open-collector input

Pull-up resistance: 2.2kΩ

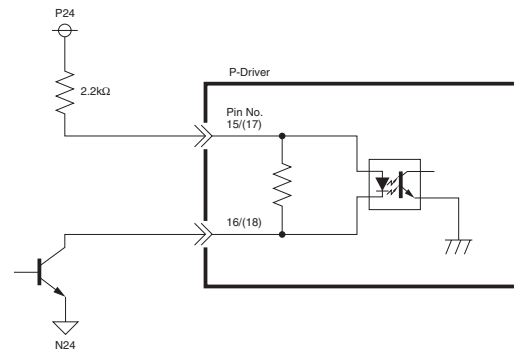

#### Feedback pulse output

Applicable line receiver: 26C32 or equivalent

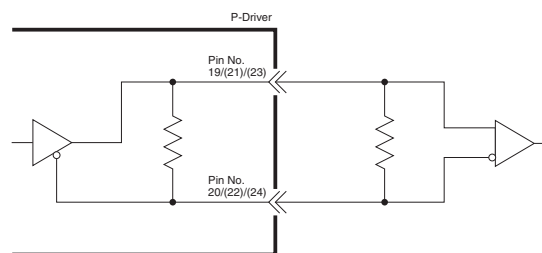

## Standard Connection Diagram

A connection diagram of P-Driver proper is provided.

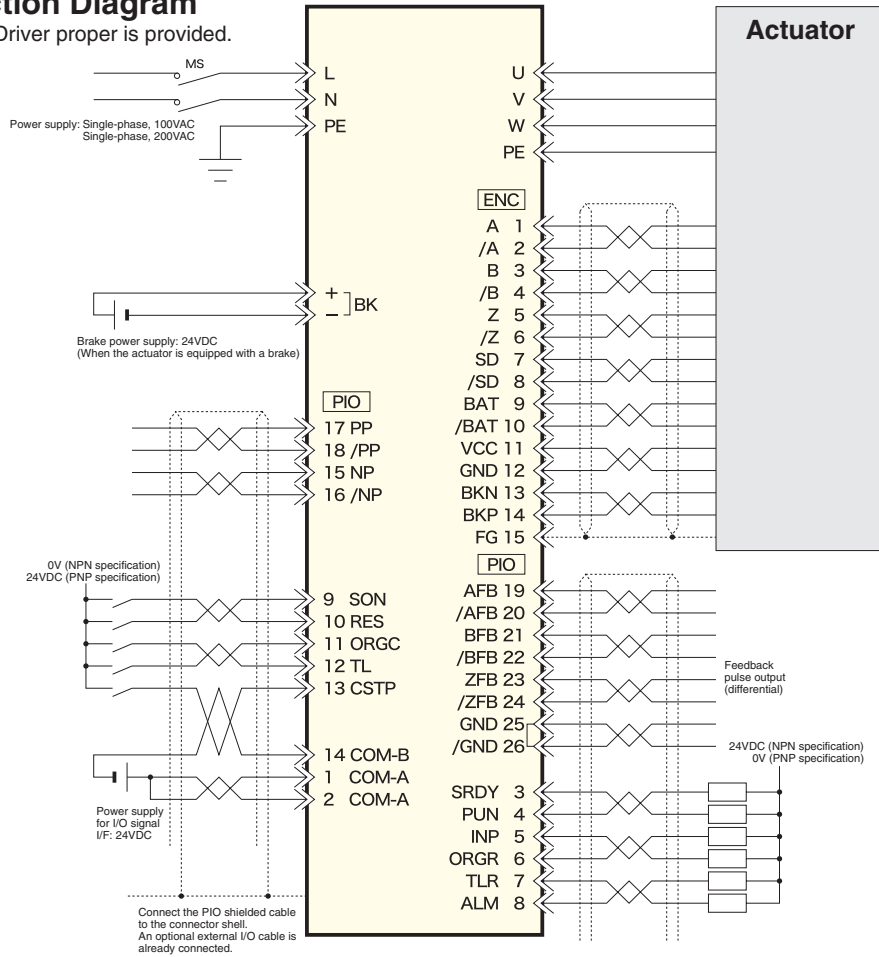

## External I/O Signals

| Pin No. | I/O category                       | Code  | Signal name             | Function   |
|---------|------------------------------------|-------|-------------------------|--|
| 1       | Power supply for I/O               | COM-A | Power-supply common (+) | Power-supply common for external I/O signals, 24VDC, connected to the + side (Pins 1 and 2 are connected internally.)                                      |
| 2       |                                    | COM-A |                         |  |
| 3       | Sequence signal output             | SRDY  | System ready            | Turns ON when control is enabled following a power input. Synchronized with ON/OFF of the corresponding LED located on the front side of the enclosure.    |
| 4       |                                    | RUN   | Operation ready         | Turns ON when the servo is turned ON (operation is enabled). Synchronized with ON/OFF of the corresponding LED located on the front side of the enclosure. |
| 5       |                                    | INP   | Positioning completion  | Turns ON when the robot enters the in-position range set by parameter.   |
| 6       |                                    | ORGR  | Homing completion       | Turns ON when homing is complete.  |
| 7       |                                    | TLR   | Torque limiting         | Turns ON when the actuator output reaches the parameter-set torque limit while TL is ON.   |
| 8       |                                    | ALM   | Alarm                   | Turns OFF when a protection circuit (function) is actuated and the base current is interrupted (this signal is normally ON).                               |
| 9       | Sequence signal input              | SON   | Servo ON                | Motor is turned on when input is on. Required for movement.  |
| 10      |                                    | RES   | Alarm reset             | Alarm is reset when this signal turns ON.  |
| 11      |                                    | ORGC  | Homing command          | Homing starts when this signal turns ON.   |
| 12      |                                    | TL    | Torque limit selection  | Limiting of actuator torque starts when this signal turns ON. (Torque limiting is cancelled when the signal turns OFF.)                                    |
| 13      |                                    | CSTP  | Forced stop             | When this signal turns ON, the robot decelerates to a stop at the forced stopping torque and the servo is turned OFF.                                      |
| 14      | Power supply for I/O               | COM-B | Power-supply common (-) | Power-supply common for external I/O signals, 24VDC, connected to the - side   |
| 15      | Command pulse input                | NP    | Pulse-train input       | Command pulse mode is specified (from 6 modes) using parameter.  |
| 16      |                                    | /NP   |                         |  |
| 17      |                                    | PP    |                         |  |
| 18      |                                    | /PP   |                         |  |
| 19      | Feedback pulse differential output | AFB   | +A                      | Position detection data is converted to pulses and output (phases A, B and Z). Pulse output mode is specified (from 6 modes) using parameter.              |
| 20      |                                    | /AFB  | -A                      |  |
| 21      |                                    | BFB   | +B                      |  |
| 22      |                                    | /BFB  | -B                      |  |
| 23      |                                    | ZFB   | +Z                      |  |
| 24      |                                    | /ZFB  | -Z                      |  |
| 25      | Reference potential                | GND   | Reference potential     | For feedback pulse output  |
| 26      |                                    | GND   |                         | Line driver ground line (Pins 25 and 26 are connected internally.)   |

### ■ Command Pulse Input Modes

| Command pulse-train mode  |   | Input terminal     | Forward | Reverse |
|---|---|--------------------|---------|---------|
| Negative logic  | Forward pulse train   | PP· /PP            |         |         |
|   | Reverse pulse train   | NP· /NP            |         |         |
|   | A forward pulse train indicates motor revolutions in the forward direction, while a reverse pulse train indicates motor revolutions in the reverse direction. |                    |         |         |
|   | Pulse train   | PP· /PP            |         |         |
|   | Sign  | NP· /NP            | Low     | High    |
|   | A command pulse indicates motor revolutions and its sign indicates the rotating direction of the motor.   |                    |         |         |
|   | Phase A/B pulse train   | PP· /PP<br>NP· /NP |         |         |
| Motor revolutions and rotating direction are specified by phases A/B (4 multiplications) with a 90-degree phase difference. |   |                    |         |         |
| Positive logic  | Forward pulse train   | PP· /PP            |         |         |
|   | Reverse pulse train   | NP· /NP            |         |         |
|   | Pulse train   | PP· /PP            |         |         |
|   | Sign  | NP· /NP            | High    | Low     |
|   | Phase A/B pulse train   | PP· /PP<br>NP· /NP |         |         |

\* Output modes of feedback pulse follow the same classification.

### ■ External Dimensions

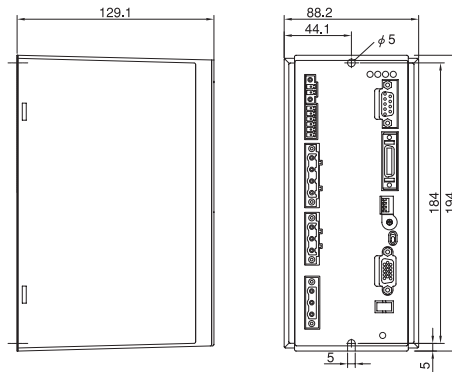

#### IAI America, Inc.

Head Office: 2690 W 237th Street, Torrance, CA 90505  
 TEL: 1-800-736-1712  
 Chicago Office: 1261 Hamilton Parkway, Itasca, IL 60143  
 TEL: 1-800-944-0333  
 New Jersey Office: 7 South Main Street, Suite-F, Marlboro, NJ 07746  
 TEL: 732-683-9101

#### IAI Industrieroboter GmbH

Ober der Röth 4, D-65824 Schwalbach am Taunus, Germany

