

ROBO Cylinder High Thrust Type

# RCP2-RFA/RFW

- Maximum push force of **6000 N** (612 kgf)
- High thrust type also suitable for use in a motorized press



### Features

- The RCP2-RFA achieves a maximum push force of 6000 N, more than seven times the maximum push force available on a conventional model (800 N).
- Its high-performance closed-loop stepper function provides a maximum of 64 positions; high positioning repeatability of  $\pm 0.02$  mm; and speed setting capability.
- Choose a desired stroke from six levels of 50 to 300 mm, and maximum push force from three levels of 1500, 3000 and 6000 N.
- Maximum vertical load capacity of 150 kg (in the case of 2.5 lead)

### Examples of Use

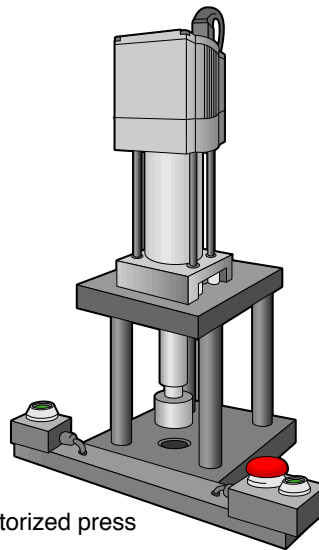

Motorized press

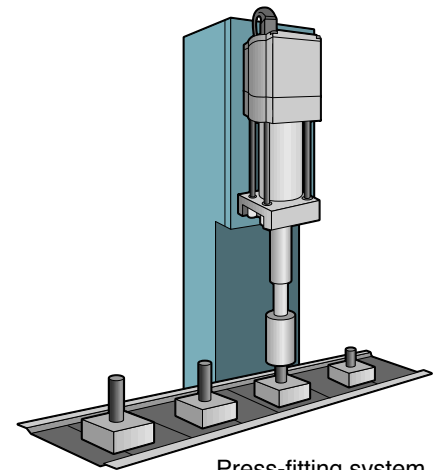

Press-fitting system

### Models

#### Actuator model

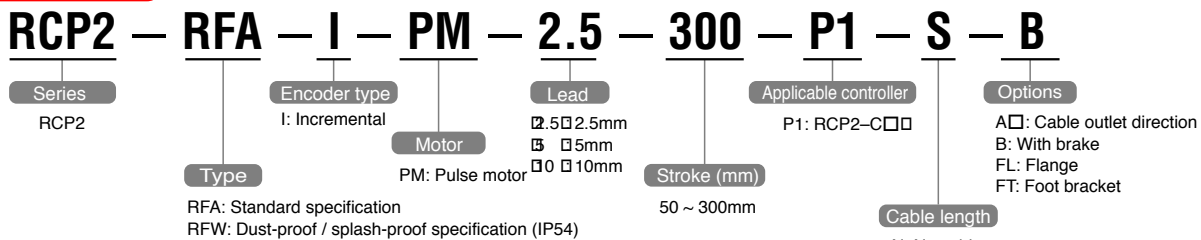

#### Controller model

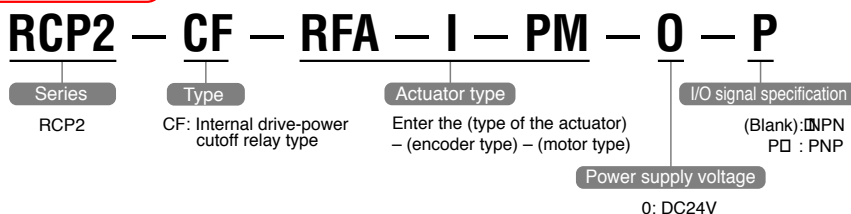

# RCP2-RFA

ROBO Cylinder High Thrust Type, Body Width 100mm, Pulse Motor

# RCP2-RFW

ROBO Cylinder High Thrust Type Dust-proof / Splash-proof Specification, Body Width 100mm, Pulse Motor

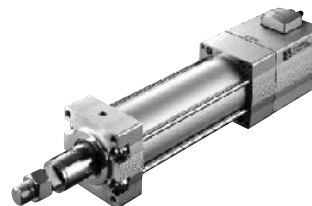

Type / Rod (100mm wide) Stroke / 50 ~ 300mm Load capacity / 300kg (horizontal)/150kg (vertical)

Model Specification Items Series — Type — Encoder type — Motor output — Lead — Stroke — Applicable controller — Cable length — Option  
 (Example) : RCP2 — RFA — I — PM — 2.5 — 300 — P1 — S — B

## Models/Specifications

\* The maximum speed of the RCP2 series will vary according to the weight of the load installed on the slider (or rod). Refer to the diagram on the back cover for the relationship of speed and load capacity.

Model	Encoder type	Motor type	Lead (mm)	Stroke (50mm increments) (mm)	Speed (Note 1) (mm/s)	Maximum load capacity (Note 2)			Maximum push force (N)
						Horizontal (kg) Rated (Note 3)   Max (Note 3)	Vertical (kg) Rated (Note 3)   Max (Note 3)		
RCP2-RFA[RFW]-I-PM-10-0-P1-0-0	Incremental	Pulse motor	10	50 ~ 300	10 ~ 250 <167>	80	47	80	1500
RCP2-RFA[RFW]-I-PM-5-0-P1-0-0			5		5 ~ 125	150	51	100	3000
RCP2-RFA[RFW]-I-PM-2.5-0-P1-0-0			2.5		1 ~ 63	300	39	150	6000

\* In the above model names, 0 the stroke, 0 the cable length, and 0 the applicable options.

## Option

Name	Type	Reference Page
Brake	B	—
With flange	FL	→P2
With foot bracket	FT	→P2

## Common Specifications

Drive system	Ball screw, rolled C10
Positioning repeatability	±0.02mm
Backlash	0.05mm or less
Guide	—
Rod diameter	φ40
Rod non-rotative accuracy (Note 4)	±1.0°
Base	Material: Aluminum with white alumite treatment
Cable length (Note 5)	N: No cable, P: 1m, S: 3m, M: 5m, X□□: Length Specification, R□□: Robot cable

## Cables

Name	Type	Remarks
Motor cable	CB-RCP2-MA□□□	Same as the RCP2-series cable
Encoder cable	CB-RFA-PA□□□	Dedicated cable for the high thrust type

## Dimensions

\* Due to its structure, the rod type is not available in the reversed-home specification. Exercise caution.

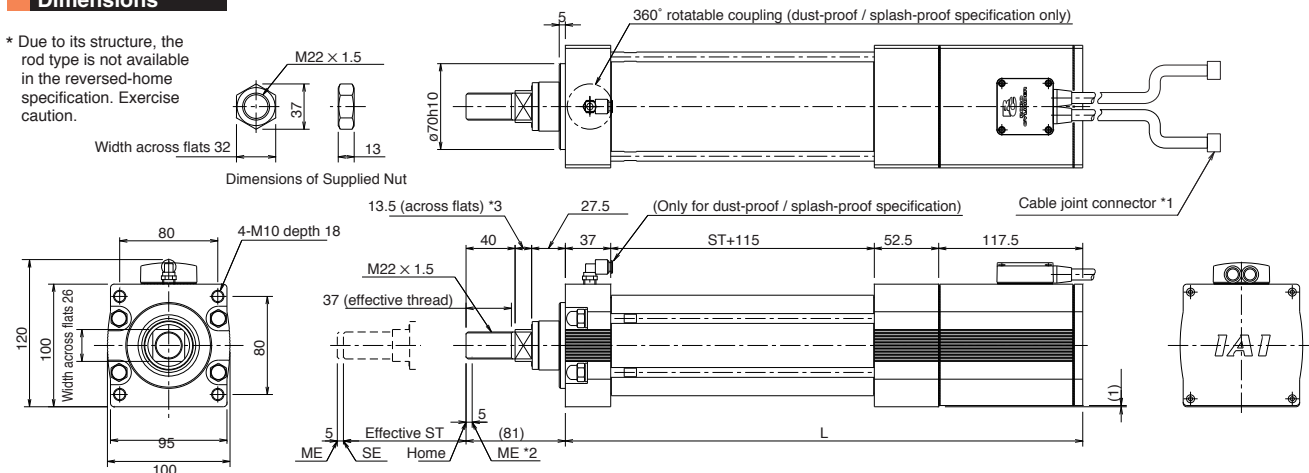

\*1. Connect the motor/encoder cables.

The motor cable is the same as the one used for the RCP2 series, but take note that the encoder cable is of a dedicated specification.

\*2. During home return the rod will move to the ME, so be careful to prevent contact with surrounding parts.

ME: Mechanical end  
SE: Stroke end

Reference dimensions are shown in parentheses.

\*3. The direction of the across flats will vary depending on the product.

### Brake Dimensions

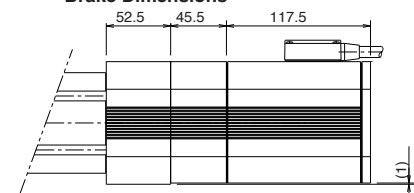

## Maximum Speed by Stroke

Stroke	50	100	150	200	250	300
L	372	422	472	522	572	622
Weight (kg)	9	9.5	10	10.5	11	11.5
Maximum speed (mm/s)	Lead: 10	250 <167>				
	Lead: 5	125				
	Lead: 2.5	63				

## Applicable Controller Specifications

Applicable controller	Maximum number of controlled axes	Compatible encoder type	Program operation	Positioner operation	Pulse-train control	Power supply voltage
RCP2-CF-RFA RCP2-CF-RFW	1 axis	Incremental	×	○	×	DC24V



(Note 1) The figures in < > applies to a vertical application.

(Note 2) Maximum load capacity remains the same regardless of the speed.

(Note 3) As to the definition of rated and max, please refer to the correlation diagram of vertical load capacity and travel life in page 2.

The above load capacity based on an acceleration of lead 10: 0.04 G, lead 5: 0.02 G, and lead 2.5: 0.01 G.

The horizontal load capacity assumes use of a guide.

(Note 4) Rod non-rotative accuracy with the guide rod retracted.

(Note 5) The maximum cable length is 20 m. Specify the desired length in meters (ex. X08 = 8 m).

## Correlation Diagram of Speed and Load Capacity

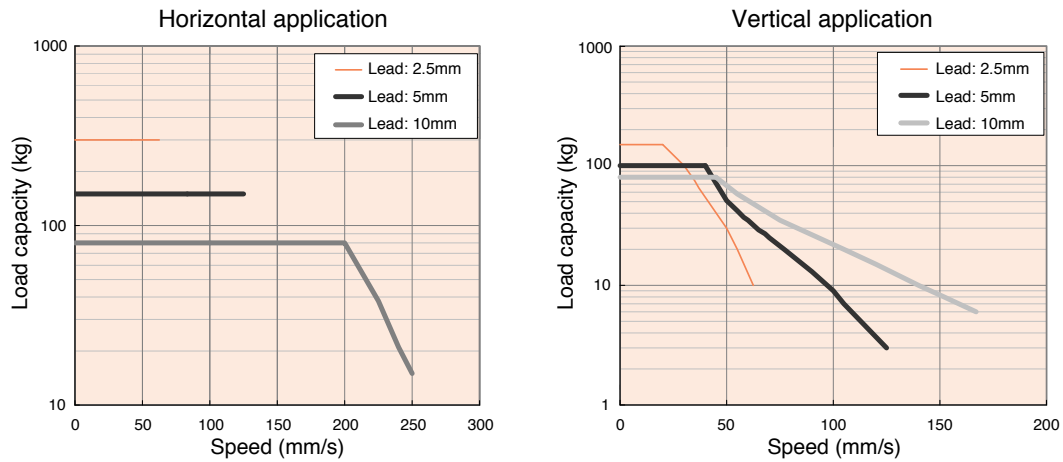

## Correlation Diagram of Vertical Load Capacity and Travel Life

- Compared with the 5,000km travel life of ROBO Cylinder Rod Type, the maximum thrust of RCP2-RFA is more powerful than other types and its travel life is dependent on the load capacity and push force.

When selecting the type using the correlation diagram of speed and load capacity or that of push force and current-limiting value, please check the travel life in the Correlation Diagram of Load Capacity and Lifetime or that of Push Force and Lifetime.

**Note:** The rated value indicates the maximum load for a travel life of 5,000km. The maximum value indicates the maximum range of operation. Please note that when operated over the rated value, the travel life will be shortened as shown on the graph below.

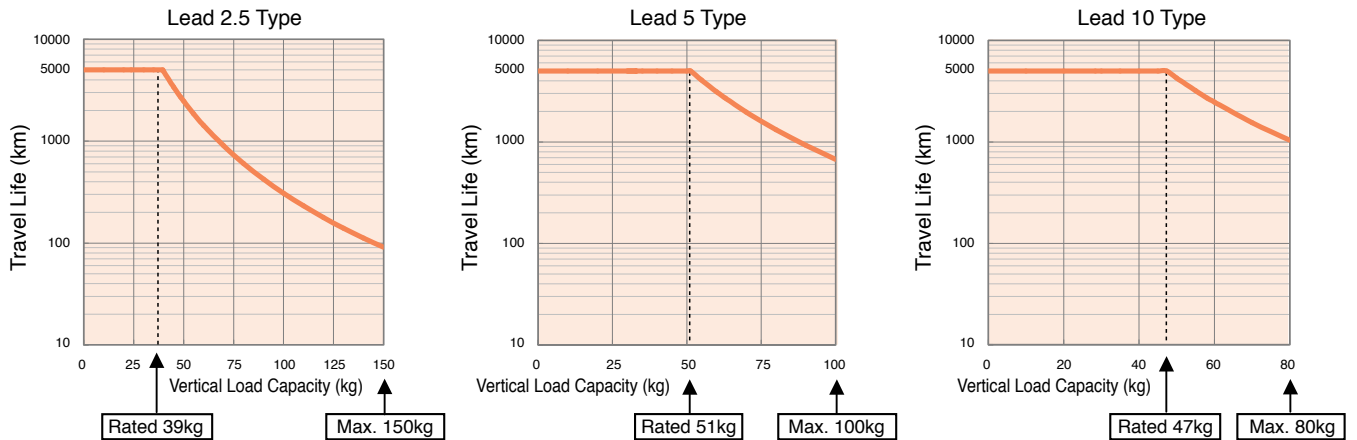

## Correlation Diagram of Push Force and Current-Limiting Value

\*The graph is provided for reference only. The actual values may vary slightly.

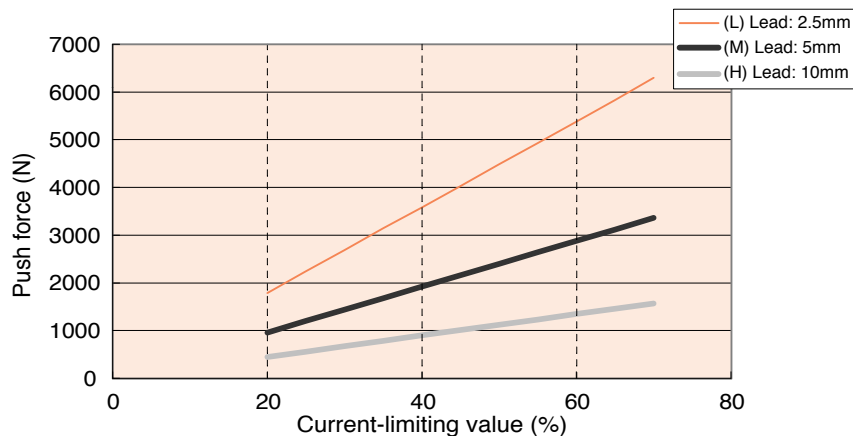

**Note:** As for the maximum number of push moves, when operated at the following lead type on the condition of the maximum push force and made move of 1mm, please refer to the chart below:

Lead (Type)	2.5	5	10
Number of push moves	1.4 million	25 million	157.6 million

\* The maximum number of push moves varies depending on the operating condition including shock and vibration. The number listed in the chart is on condition that there is no shock and vibration.

**Options (Free of Charge)**

Cable Outlet Direction

Motor Direction (Standard)  
(Code: Left blank)

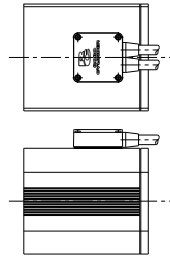

Left  
(Code: A1)

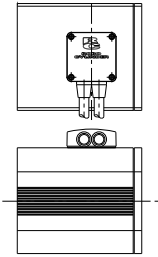

Rod Direction  
(Code: A2)

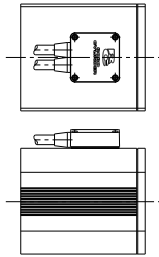

Right  
(Code: A3)

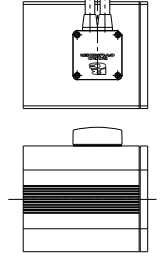

**Options (Additional Charge)**

Foot Bracket (Code: FT)

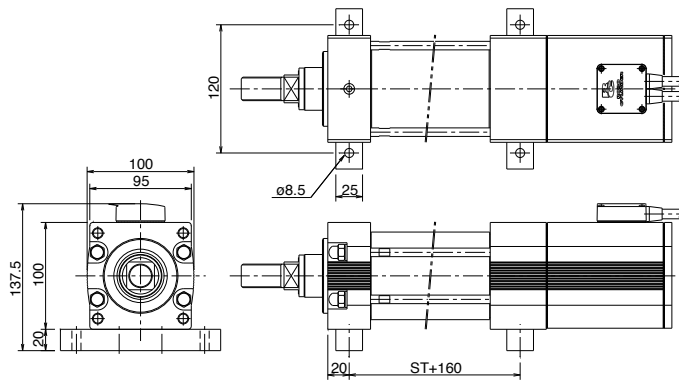

Mounting Flange (Code: FL)

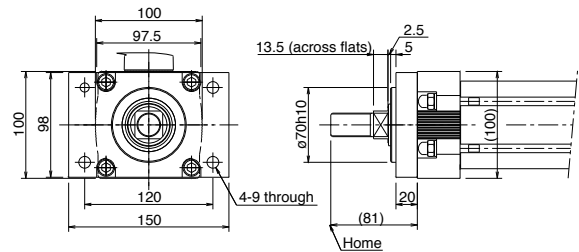

**IAI America, Inc.**  
Head Office 2690 W 237th Street, Torrance, CA 90505  
Chicago Office: 1261 Hamilton Parkway Itasca, IL 60143

**IAI Industrieroboter GmbH**  
Ober der Röth 4, D-65824 Schwalbach am Taunus, Germany

Home Page: [www.intelligentactuator.com](http://www.intelligentactuator.com)  
The information contained in this catalog is subject to change without notice for the purpose of product improvement.

