

RCP2-RMW

ROBO Cylinder Rod Type: Unit Width 64mm, Pulse Motor, Dustproof, Splash-Proof Specification



Type / Rod (64mm wide), standard Stroke / 50~300mm Load capacity / 55kg (horizontal)/26kg (vertical)

Model Specification Items - Series - Type - Encoder type - Motor - Lead - Stroke - Applicable controller - Cable length - Options
 (Example) RCP2 - RMW - I - PM - 8 - 300 - P1 - S - B

* Refer to page 37 for the details of the model specification items.

* The maximum speed limit of the RCP2 Series will vary according to the weight of the load on the slider (rod). Refer to Correlation Diagrams of Speed and Load Capacity on page 30.

Model/Specifications

Model	Encoder type	Motor	Lead (mm)	Stroke 50mm increments (mm)	Speed (mm/s)	Load capacity (Note 1)		Maximum push force (N)
						Horizontal (kg)	Vertical (kg)	
RCP2-RMW-O-PM-16-***-P1-△-□	Absolute Incremental	Pulse motor	16	50~300	10~320 <265>	40~20	5~1	240
RCP2-RMW-O-PM-8-***-P1-△-□			8		5~200	50	17.5~2	470
RCP2-RMW-O-PM-4-***-P1-△-□			4		1~100	55	26~5	800

* In the above model names, O indicates the encoder type, *** the stroke, △ the cable length, and □ the applicable options.

Options

Name	Model	Page
Brake	B	→P137
With flange	FL	→P138
With foot bracket	FT	→P139

Common Specifications

Drive system	Ball screw Ø12mm, rolled C10
Positioning repeatability	±0.02mm
Backlash	0.05mm or less
Guide	—
Rod diameter	Ø30mm
Rod non-rotative accuracy	±1.0°
Base	Material: Aluminum with white alumite treatment
Cable length (Note 3)	N: No cable, P: 1m, S: 3m, M: 5m, X□□: Length specification, R□□: Robot cable

Dimensions

* Due to its structure, the rod type is not available in the reversed-home specification. Exercise caution.

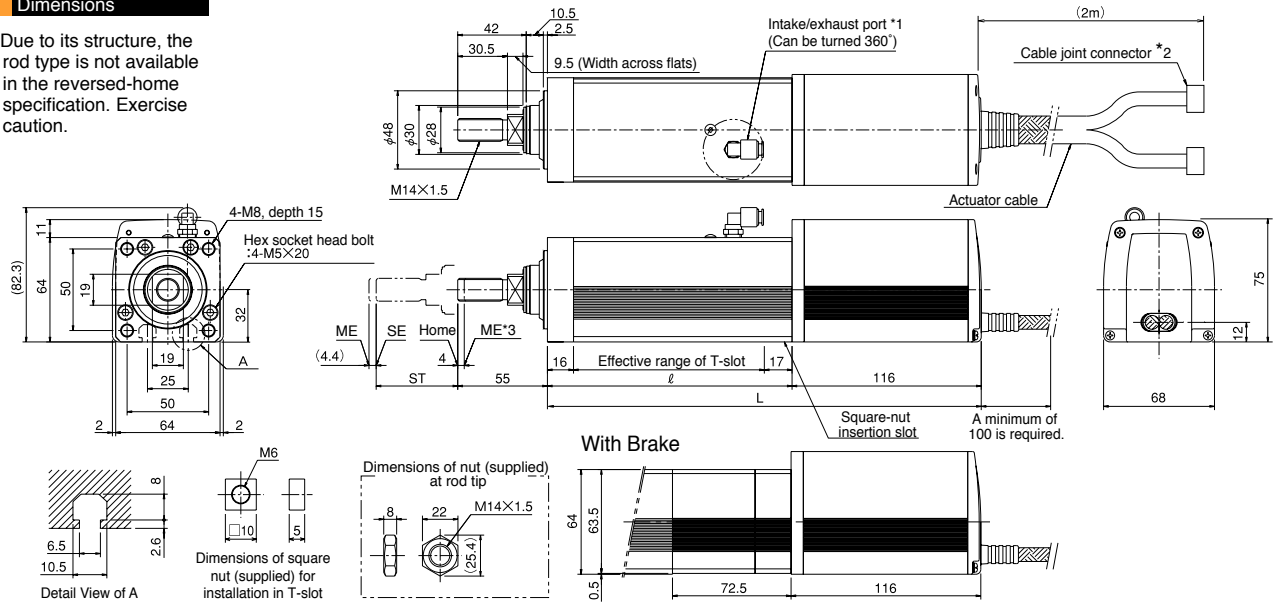

Dimensions, Weight and Maximum Speed by Stroke

*The figures in parentheses apply to the brake type, while those in < > apply to a vertical application.

Stroke	50	100	150	200	250	300
ℓ	150	200	250	300	350	400
L	266 (338.5)	316 (388.5)	366 (438.5)	416 (488.5)	466 (538.5)	516 (588.5)
Weight (kg)	3.5	4.0	4.5	5.0	5.5	6.0
Maximum speed (mm/s)	Lead 16	320 <265>				
	Lead 8	200				
	Lead 4	100				

- *1. The intake/exhaust port is a pipe for bleeding air from the interior of the □ actuator. Connect a tube with a diameter of Ø 6 and extend the line to an □ area free from water splashes.
- *2. Connect the motor/encoder cables. Refer to page 160 for details on these □ cables.
- *3. During home return the rod will move to the ME, so pay attention to prevent □ contact with surrounding parts.
- ME: Mechanical end
- SE: Stroke end
- The values in parentheses are reference dimensions.

Applicable Controller Specifications

Applicable Controller	Maximum number of controlled axes	Compatible encoder type	Program operation	Positioner operation	Pulse-train control	Power-supply voltage	Page
RCP2-C	1 axis	Absolute	X	O	X	24VDC	→P151
RCP2-CG	1 axis	Incremental	X	O	X		→P151

Caution

(Note 1) The Figures in < > apply to a vertical application.
 (Note 2) The load capacity is based on operation at an acceleration of 0.2 G.
 (Note 3) The maximum cable length is 15 m for the absolute type and 20 m for the incremental type. Specify the desired length in meters (e.g., X08 = 8 m).

* Refer to page 23 for other points to note.