

The New ROBO Cylinder that's 25mm x 25mm Super Slim Type is here!

ROBO Cylinder Super Slim Type RCP2-RPA



Benefits

- **Super Slim size of 25mm wide and 25mm high***
With a unit size of 25mm wide and 25mm high, it is now possible to install the unit through a small opening. It also becomes possible to make the size of the application smaller.
□ The height of the motor is 42mm.
- **Convenient Functions of the Electric Cylinder**
 1. Maximum of 64 Positioning Points
 2. Incremental Motion Function
 3. Maximum Push Force of 100N
 4. Halt Function / Zone Signaling

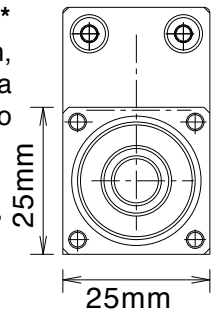

Application Examples

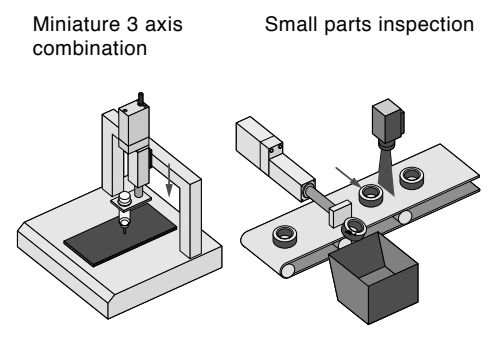

Model

Actuator Model

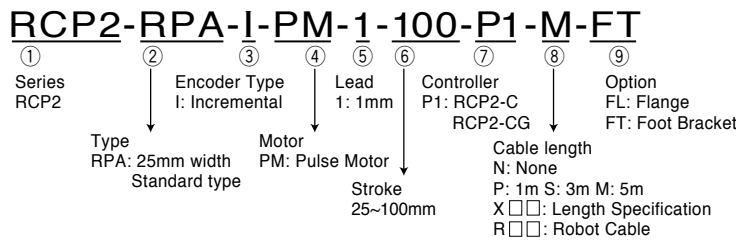

Controller Model

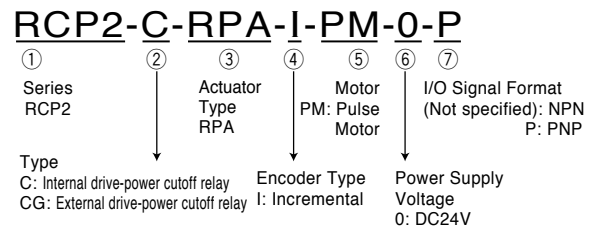

Push Force

Although the RCP2-RPA is an electric cylinder, it can continually push against a load just like an air cylinder. By adjusting the setting of the controller, it is possible to change the push force from 50N to a maximum of 100N.

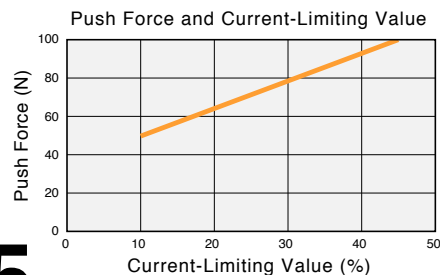

Options

Flange

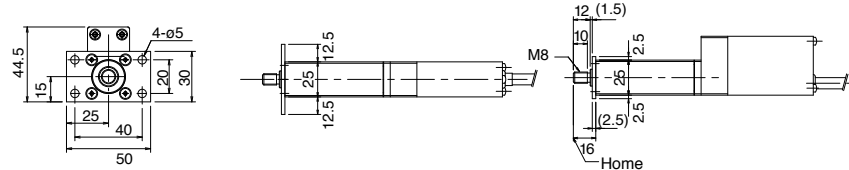

Foot Bracket

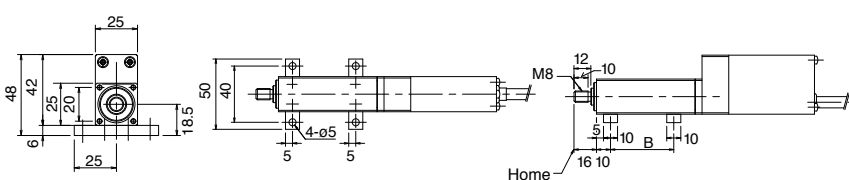

RCP2-RPA

ROBO Cylinder Rod Type: Unit Width 25mm, Pulse Motor, Straight (Form) Type

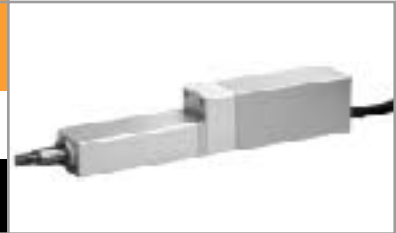

Type / Rod (25mm wide) Stroke / 25~100mm Load capacity / 7kg (horizontal)/2.5kg (vertical)

Model details Series Type Encoder type Motor Lead Stroke Applicable controller Cable length Options
 RCP2-RPA-I-PM-1-100-P1-S-FL

Model/Specifications

Model	Encoder type	Motor	Lead (mm)	Stroke 25mm increments (mm)	Speed (mm/s)	Load capacity (Note 1)		Maximum push force (N)
						Horizontal (kg)	Vertical (kg)	
RCP2-RPA-I-PM-1-□□□-P1-□-□□	Incremental	Pulse motor	1	25~100	1~25	7	2.5	100

* In the above model names, □□□ indicates the stroke, □ the cable length and □□ the applicable options.

Options

Name	Model	Page
With flange	FL	-
With foot bracket	FT	-

Common Specifications

Drive system	Ball screw ø6mm, rolled C10 (Ball screw is driven by a 1/2 ratio reduction gear.)
Repeatability	±0.02mm
Backlash	0.05mm or less
Guide	-
Life expectancy	2,000km
Rod diameter	ø12mm
Rod non-rotative accuracy	±2.1°
Base	Material: Aluminum with white alumite treatment
Cable length (Note 2)	N: No cable, P: 1m, S: 3m, M: 5m X □□: Length specification, R □□: Robot cable

Dimensions

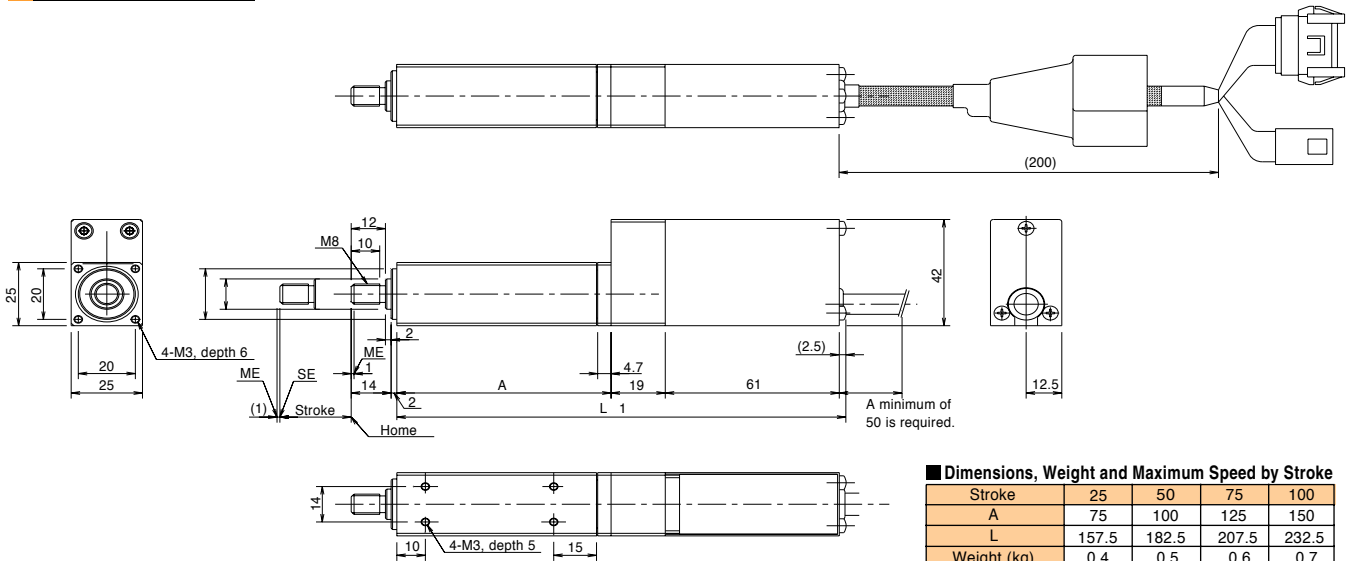

Dimensions, Weight and Maximum Speed by Stroke

Stroke	25	50	75	100
A	75	100	125	150
L	157.5	182.5	207.5	232.5
Weight (kg)	0.4	0.5	0.6	0.7
Maximum speed (mm/s)	Lead 1: 25			

Applicable Controller Specifications

Applicable Controller	Maximum number of controlled axes	Compatible encoder type	Program operation	Positioner operation	Pulse-train control	Power-supply voltage	Page
RCP2-C	1 axis	Incremental	X	○	X	24VDC	-
RCP2-CG	1 axis		X	○	X		-



(Note 1) The load acceleration is 0.05G. When moving a load horizontally, use the guide together with the rod and radial load in a state where it does not catch.

(Note 2) The maximum cable length is 20m. Specify the desired length in meters (e.g., X08=8m).