

# RCS-RA45-GD

ROBO Cylinder Rod Type: Unit Width 45mm, 30W, Slim Shape w/ Double Guides

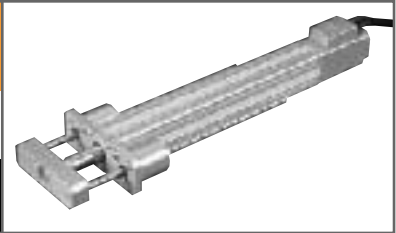

Type	Rod (45mm wide) w/ double guides	Stroke	50~200mm	Load capacity	30kg (horizontal)/8kg (vertical)
------	----------------------------------	--------	----------	---------------	----------------------------------

Model specification items: Series Type Encoder type Motor Guide type Speed type Stroke Cable length Options  
 (Example) RCS -RA45- A - 30 - GD - H - 200 - S - B

\* Refer to page 37 for the details of model specification items.

## Model/Specifications

Model	Encoder type	Motor	Lead (mm)	Stroke 50mm increments (mm)	Speed (mm/s)	Load capacity (Note 1)		Rated thrust (N)
						Horizontal (kg)	Vertical (kg)	
RCS-RA45-○-30-GD-H-***-△-□	Absolute Incremental	30	10	50~200	1~500	7	1	51
RCS-RA45-○-30-GD-M-***-△-□			5		1~250	15	3.5	101.9
RCS-RA45-○-30-GD-L-***-△-□			2.5		1~125	30	8	202.9

\* In the above model names, ○ indicates the encoder type, \*\*\* indicates the stroke, △ the cable length, and □ the applicable options.

## Options

Name	Model	Page
Different connector-cable outlet direction	A2	→P137
Brake	B	→P137
With foot bracket	FT	→P139

## Common Specifications

Drive system	Ball screw Ø8mm, rolled C10
Positioning repeatability	±0.02mm
Backlash	0.05mm or less
Guide	Ball bush guide x 2 (externally attached)
Rod diameter	Ø20mm
Rod non-rotational accuracy	±0.08°
Base	Material: Aluminum with white alumite treatment
Cable length (Note 2)	P: 1m, S: 3m, M: 5m, X□: Length specification, R□: Robot cable

## Dimensions

\* Please note that due to its structure, the rod type is not available in the reversed-home specification.

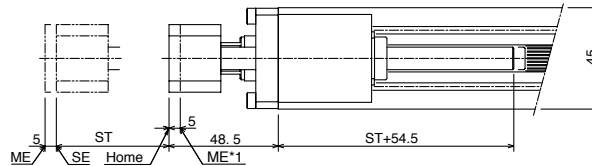
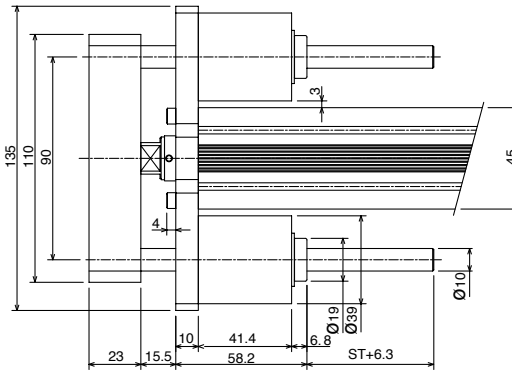
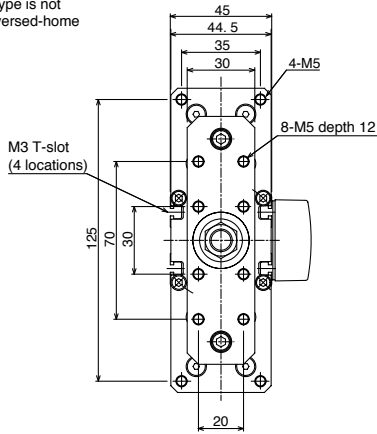

ST: Stroke  
SE: Stroke end  
ME: Mechanical end

\*1 During home return the slider will move to the ME, so be careful to prevent contact with surrounding parts.

\* For the actuator dimensions, refer to the dimensions of the RCS-RA45-GN on page 96

### Weight by Stroke

Stroke	50	100	150	200
Weight (kg)	2.1	2.4	2.7	3.0

## Applicable Controller Specifications

Applicable Controller	Maximum number of controlled axes	Compatible encoder type	Program operation	Positioner operation	Pulse-train control	Power supply voltage	Page
RCS-C	1 axis	Absolute/Incremental	X	O	X	24VDC	→P163
RCS-E	1 axis		X	O	X	24VDC	→P163



(Note 1) The load capacity is based on operation at an acceleration of 0.3 G (or 0.2 G for the L type). The horizontal load capacity assumes a condition where a guide or guides are used to prevent the rod from receiving radial loads. If no guide is used, refer to the correlation diagrams of allowable tip load and traveling life on page 133.  
 (Note 2) The maximum cable length is 15 m. Specify the desired length in meters (e.g., X08 = 8 m).

\* Refer to page 23 for other points to note.