

RCS-RB7525-GN

ROBO Cylinder Rod Type: Unit Width 75mm, 60W, Short Shape w/o Guide



Type	Rod (75mm wide) w/o guide	Stroke	50~300mm	Load capacity	45kg (horizontal)/7kg (vertical)
------	---------------------------	--------	----------	---------------	----------------------------------

Model specification items: Series Type Encoder type Motor Guide type Speed type Stroke Cable length Options
 (Example) RCS - RB7525 - I - 60 - GN - H - 300 - S - B

* Refer to page 37 for the details of model specification items.

Model/Specifications

Model	Encoder type	Motor (W)	Lead (mm)	Stroke 50mm increments (mm)	Speed (mm/s) (Note 1)	Load capacity (Note 2)		Rated thrust (N)
						Horizontal (kg)	Vertical (kg)	
RCS-RB7525-I-60-GN-H-***-△-□	Incremental	60	10	50~300	1~500	25	4	101.9
RCS-RB7525-I-60-GN-M-***-△-□			5		1~250	45	7	203.8

* In the above model names, *** indicates the stroke, △ the cable length, and □ the applicable options.

Options

Name	Model	Page
Different connector-cable outlet direction	A1~A3	→P137
Brake	B	→P137
With flange	FL	→P139
With foot bracket	FT	→P139

Common Specifications

Drive system	Ball screw Ø8mm, rolled C10
Positioning repeatability	±0.02mm
Backlash	0.05mm or less
Guide	No guide
Rod diameter	Ø25mm
Rod non-rotational accuracy	±0.7°
Base	Material: Aluminum with white alumite treatment
Cable length (Note 3)	P: 1m, S: 3m, M: 5m, X□□: Length specification, R□□: Robot cable

Dimensions

* Please note that due to its structure, the rod type is not available in the reversed-home specification.

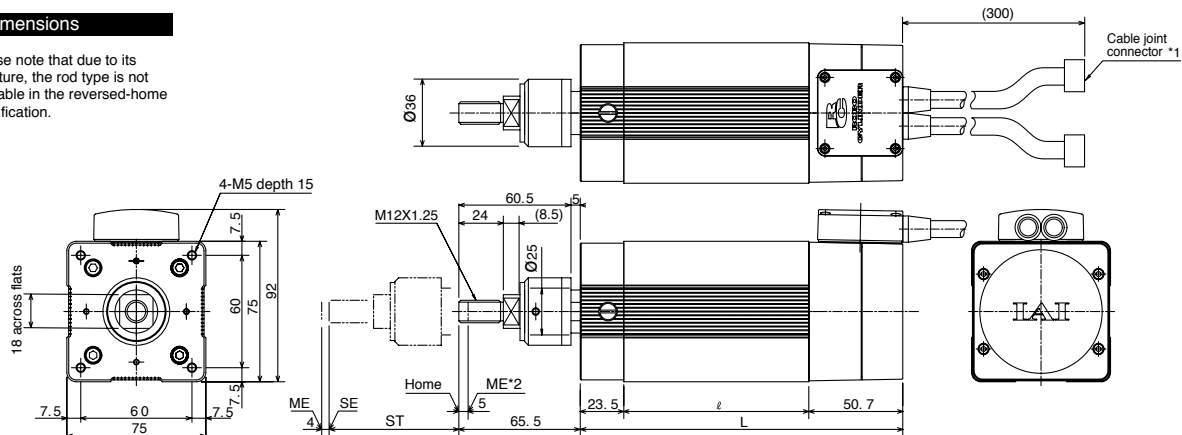

*1 Connect the motor/encoder cables. Refer to page 171 for details on the cables.

*2 During home return the rod will move to the mechanical end, so pay attention to prevent contact with surrounding parts.

ST: Stroke
SE: Stroke end
ME: Mechanical end

Brake Dimensions

The overall length (L) of the brake type is 35.5 mm longer than that of the standard type (refer to the table shown below).

*3 Please note that if you choose a 50-mm stroke, only a single row of mounting holes (2 holes) are provided in the bottom surface.

Dimensions, Weight and Maximum Speed by Stroke

Stroke	50	100	150	200	250	300
ℓ	49.8	99.8	149.8	199.8	249.8	299.8
L	124	174	224	274	324	374
N	-	1	2	3	4	5
n	2	4	6	8	10	12
Weight (kg)	1.9	2.4	2.8	3.3	3.7	4.2
Maximum speed (mm/s)	H type		500		485	350
	M type		250		245	175

Applicable Controller Specifications

Applicable Controller	Maximum number of controlled axes	Compatible encoder type	Program operation	Positioner operation	Pulse-train control	Power supply voltage	Page
RCS-C	1 axis	Incremental	X	O	X	24VDC	→P163
RCS-E	1 axis		X	O	X	24VDC	→P163



(Note 1) A longer stroke will result in a lower maximum speed to prevent the ball screw from reaching a dangerous speed. (Refer to the above table for the maximum speed at a given stroke.)
 (Note 2) The load capacity is based on operation at an acceleration of 0.1 G for the H type and 0.08 G for the M type (each represents the maximum acceleration for the applicable type). The horizontal load capacity assumes a condition where a guide or guides are used to prevent the rod from receiving radial loads.
 (Note 3) The maximum cable length is 15 m. Specify the desired length in meters (e.g., X08 = 8 m).

* Refer to page 23 for other points to note.