

# RCS-RB7530-100-GN

ROBO Cylinder Rod Type: Unit Width 75mm  
100W, Short Shape w/o Guide

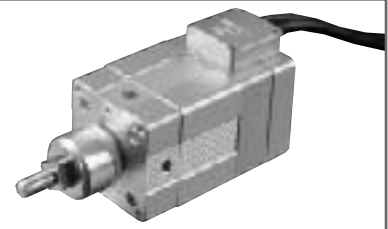

Type Rod (75mm wide) w/o guides Stroke 50~300mm Load capacity 30kg (horizontal)/12.5kg (vertical)

Model specification items Series Type Encoder type Motor Guide type Speed type Stroke Cable length Options  
(Example) RCS - RB7530 - I - 100 - GN - H - 300 - S - B

\* Refer to page 37 for the details of model specification items.

## Model/Specifications

Model	Encoder type	Motor (W)	Lead (mm)	Stroke 50mm increments (mm)	Speed (mm/s) (Note 1)	Load capacity (Note 2)		Rated thrust (N)
						Horizontal (kg)	Vertical (kg)	
RCS-RB7530-I-100-GN-H-***-△-□	Incremental	100	12	50~300	1~600	15	5.5	141.1
RCS-RB7530-I-100-GN-M-***-△-□			6		1~300	30	12.5	283.2

\* In the above model names, \*\*\* the stroke, △ the cable length, and □ the applicable options.

## Options

Name	Model	Page
Different connector-cable outlet direction	A1~A3	→P137
Brake	B	→P137
With flange	FL	→P139
With foot bracket	FT	→P139

## Common Specifications

Drive system	Ball screw $\phi$ 10mm, rolled C10
Positioning repeatability	$\pm$ 0.02mm
Backlash	0.05mm or less
Guide	No guide
Rod diameter	$\phi$ 30mm
Rod non-rotational accuracy	$\pm$ 0.7°
Base	Material: Aluminum with white alumite treatment
Cable length (Note 3)	P: 1m, S: 3m, M: 5m, X□□: Length specification, R□□: Robot cable

## Dimensions

\* Please note that due to its structure, the rod type is not available in the reversed-home specification.

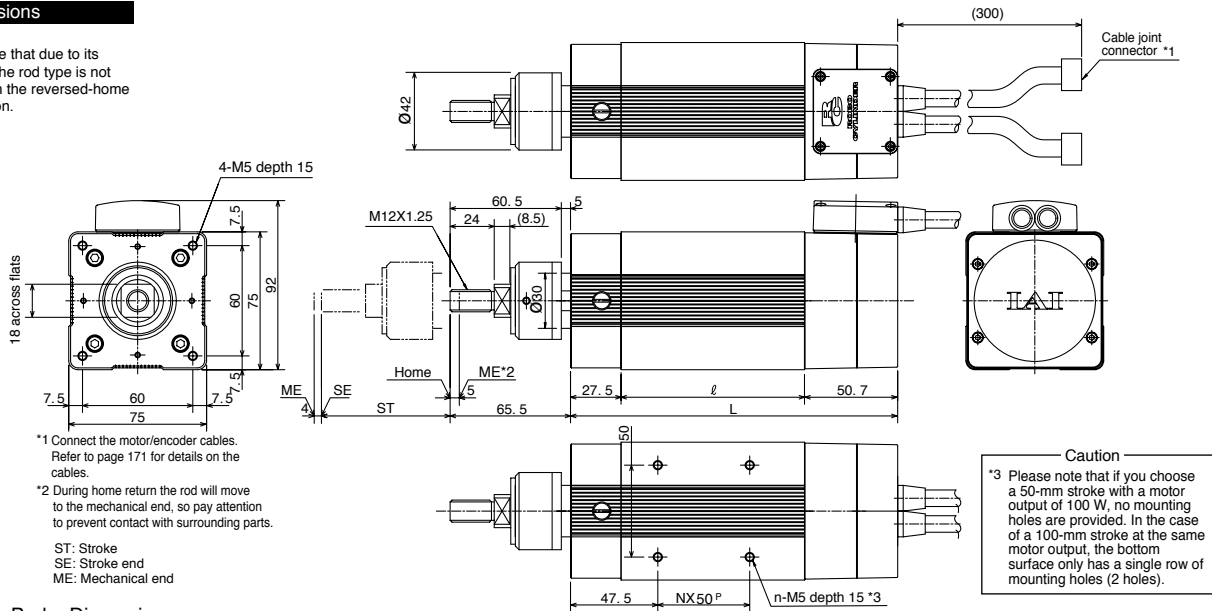

### Brake Dimensions

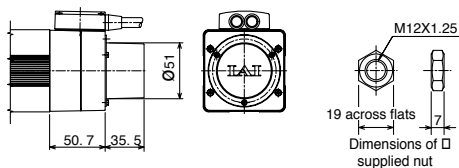

### Dimensions, Weight and Maximum Speed by Stroke

Stroke	50	100	150	200	250	300
$\ell$	49.8	99.8	149.8	199.8	249.8	299.8
L	128	178	228	278	328	378
N	-	-	1	2	3	4
n	-	2	4	6	8	10
Weight (kg)	2.2	2.7	3.1	3.6	4.0	4.5
Maximum speed (mm/s)	H type 600 M type 300					505 250

## Applicable Controller Specifications

Applicable Controller	Maximum number of controlled axes	Compatible encoder type	Program operation	Positioner operation	Pulse-train control	Power supply voltage	Page
RCS-C	1 axis	Incremental	X	O	X	AC100/200V	→P163
E-Con	1 axis	Incremental	X	O	X	AC100/200V	Refer to the separate catalog.
P-Driver	1 axis	Incremental	X	X	O	AC100/200V	
X-SEL	4 axes	Incremental	O	△	X	AC100/200V	

**Caution**  
(Note 1) A longer stroke will result in a lower maximum speed to prevent the ball screw from reaching a dangerous speed. (Refer to the above table for the maximum speed at a given stroke.)  
(Note 2) The load capacity is based on operation at an acceleration of 0.2 G for the H type and 0.1 G for the M type (each represents the maximum acceleration for the applicable type). The horizontal load capacity assumes a condition where a guide or guides are used to prevent the rod from receiving radial loads.  
(Note 3) The maximum cable length is 15 m. Specify the desired length in meters (e.g., X08 = 8 m).

\* Refer to page 23 for other points to note.